

CromPack[®]

vacuum packaging machines



VM 51 XL SERIES

Crompack VM Series products, the use of advanced graphic display and a choice of 4 different languages has been made very easy. The principle of respect for nature set out Crompack products, food products using appropriate codex. Crompack brand products are CE certified and RoHS standards are made.



VM SERIES vacuum packaging machines

TECHNICAL DATA



DIMENSIONS

Machines Dimensios	mm	585*631*460 h
Chamber Size	mm	520*500*250 h
Pump	mc/h	28 m3
Sealing Bar	mm	510 mm
Power	Voltage	220 volt-50/60 Hz
Kw / h	Kw	0,75
Weight	Kg	95
Closing Operation	Sec	15-25

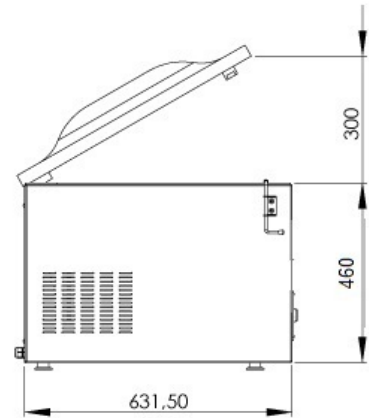
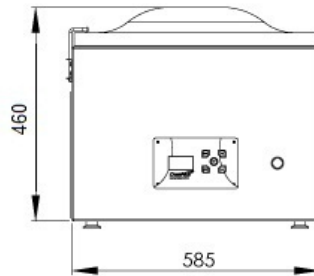
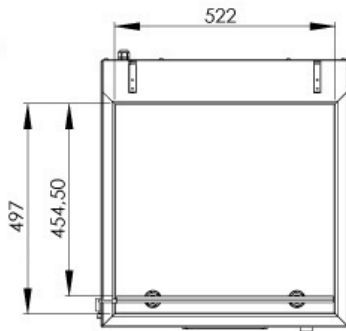

SEALING JAW

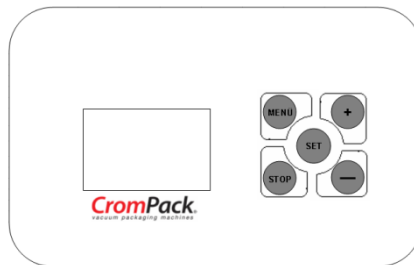

LCD PANEL

